



**Multihog**<sup>®</sup>

**CV 350** MORE THAN JUST A SWEEPER!

# THE MULTIHOV CV: HIGHLIGHTS

---



Compact, multi-purpose sweeper available in 3500 kg (7716 lb) or 4000 kg (8818 lb) GVW models.

Dedicated all-terrain vehicle with the option to change front brushes to other attachments.

Incredibly simple operation – switch from drive mode to sweep mode and back again using one button.

Low emission Tier 4 Final/Stage V engine makes the CV a more sustainable choice.

All sweeper functions are controlled from a fully adjustable, floating ergonomic armrest.



## **A SWEEPER OF SUPERIOR QUALITY, DESIGNED & BUILT IN IRELAND.**

---

Launched in 2008, Multihog has been a leader in the multi-purpose vehicle field for many years. Designed and produced in our Irish factory, we export our products across the globe to a wide range of customers including municipalities, airports and contractors.

Our R&D department is constantly innovating, and is led by our directors, who share more than 75 years of machinery production experience:

### **Jim Mc Adam - CEO**

Jim is a trained engineer, and spent a large part of his career as MD of Moffett Ltd., the reverse drive tractor & truck-mounted forklift manufacturer.



### **Gerry McHugh - Technical Director**

Gerry also began his career as an engineer with Moffett Ltd., before taking over as MD of Aisle-Master, where he led the development of the narrow aisle forklift.



# PERFORMANCE

The performance of the Multihog CV sweeper really is class-leading. To create the most sustainable sweeper possible, our engineers prioritised a combination of powerful functionality and reduced fuel usage.



50% gradeability for steep streets



Hopper capacity is 1.5 m<sup>3</sup> (2 cubic yards) and boasts industry-leading suction power of 8000m<sup>3</sup> (4700 cfm).

Fully hydrostatic drive train for smooth driving and four cooler sections for fuel, air, water and hydraulic oil to help save costs.

With the ability to climb hills with up to 50% incline, the CV is ideal for sweeping even the steepest of paths and streets.

Brushes can adapt from 1.2 m (47") up to 2.35 m (93") working width, and are tiltable for easy operation around gutters.

# SUSTAINABILITY



200 litre (52 gal) recirculation tank provides superb dust suppression and helps to reduce water usage.



Integrated airflow enhancer optimises operation at lower RPM, reducing fan noise and fuel usage.



Powerful performance at lower fan speed and engine RPM ensures noise pollution is minimised for night operation.



The CV achieved the gold standard of 4 stars on the PM10/PM2.5 industry standard test.



Incredibly simple operation – switch from drive mode to sweep mode and back again using one button.



Operating the CV with more sustainable biofuels can help to reduce net greenhouse gas emissions by up to 90%.

# SIMPLIFIED SERVICING

---

1. Everything in the rear engine bay is very accessible for servicing. The oil, fuel and air filters are all within reach when you open the doors, making filter changes very easy. The battery & fuel tank are also built into the openable door, so they don't obstruct anything during maintenance.
2. The hopper is manufactured from a special grade of aluminium alloy, which is anti-corrosive and perfect for harsh weather conditions.
3. The mesh inside the hopper is made from stainless steel and does not need to be removed for cleaning. The rear grill is also removable for access to jump points, electrical box and alternator belt.
4. The centre point of the CV is very streamlined and easily greasable, with no PTO shaft and minimal hoses running through it, for less wear and less maintenance.



SCAN  
ME 





# AIR QUALITY & SAFETY



The Multihog CV sweeper achieved the highest rating available (4 stars) on the PM10/PM2.5 test. The PM tests measure particulate matter and how it's handled during sweeping, and are considered the industry's 'gold standard' for prevention of air pollution.

From a safety perspective, the CV has a ROPS-certified cab and also carries European Type Approval, which means that it is a road-legal tractor which complies with some of the world's strictest safety standards. Being classified as a tractor often means that the operator only requires a tractor licence to operate our sweeper (*region-specific*).

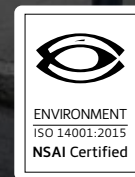
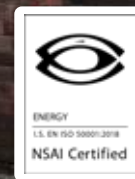

# SO MUCH MORE THAN A SWEEPER

---

The Multihog CV is built to work all year round, with a wide range of front and rear attachments. Swapping attachments is simple - the front brushes can be removed in less than 15 minutes, and the hopper within just 5 minutes.

Other ways to get the most out of your CV:

1. The rear rails can be used for a drop spreader.
2. Optional pressure washer can be built in to the back of the hopper for cleaning park benches, trash cans, etc. Can also be useful for cleaning out the hopper itself using water from the fresh water tank.
3. With the water nozzle connections at the front, the sweeper is already set up to supply water at the front to other attachments such as a scrubber or watering arm.
4. Towing capacity of 3.5 tonne (braked trailer) allows you to transport extra equipment to job sites, e.g. extra water tanks.

**SEE IT IN ACTION!**



**SCAN  
ME** 





# EXCEPTIONAL COMFORT

---

- Spacious cab with air-suspended seat and excellent visibility.
- Adjustable seat height and steering column position.
- Unparalleled cooling with separate fan for supercharged a/c.
- Independent spring & damper suspension for a smooth ride.
- Insulated cab protects operator from external noise & vibration.
- Ergonomic armrest moves with the operator for extra comfort.



# SIMPLE OPERATION

---

- Our 'one-push-sweeping' via green button on armrest means operation is simple. Controlling 8 sweeping functions in one, it allows the operator to turn the key, push the green button and start sweeping right away.
- Just 2 simple drive modes – drive mode for driving and work mode for operating (e.g. sweeping/mowing).
- Large HD display in the cabin shows various functions, including brush speed, water level, suction power, etc.
- Everything is adjustable from within the cabin, and the ergonomic armrest makes operation very comfortable.
- A key feature is the ability to pre-set operating modes for different attachments, e.g. mower mode or snow plow mode. The modes will have different hydraulic flows optimised for each task, and takes the guesswork out of setting up attachments for less experienced operators or seasonal crew members, reducing downtime and costs.





## REDUCE YOUR COSTS WITH THE CV

---

- Truly multi-purpose sweeper, for use 365 days each year to maximise your capital investment.
- Compact size makes it perfect for sidewalk maintenance, and having the right machine for the right task ensures you don't waste fuel running an oversized vehicle for the task at hand.
- 200 litre (52 gal) water recirculation system minimises return trips to a depot for refills, saving time and costs.
- Easy maintenance and excellent access to rear chassis reduces service time, and in turn, downtime.
- Hopper is manufactured from a special grade of anti-corrosive aluminium alloy, extending its lifespan in harsh conditions.
- Reduced number of greasing points with auto-lubrication option to save on servicing costs.
- On-board diagnostics streamline troubleshooting and get you back to work faster, with less downtime.
- CAN bus system lowers the number of electrical wires and hoses running through the machine, reducing wearable parts.
- Wear-resistant blades on heavy-duty fan extends its lifespan.
- Integrated airflow enhancer significantly decreases fuel usage, making the CV a more sustainable choice.

# TECHNICAL SPECIFICATION

- Engine: Hatz, 75 hp
- Emissions: Stage V, Tier 4 final
- Length: 3800 - 4600 mm (149 - 181 in)
- Width: 1200 - 1600 mm (47 - 63 in)
- Height: 1995 mm (79 in)
- Wheelbase: 1750 mm (69 in)
- Unladen weight: 2000 - 2500 kg (4409 - 5511 lb)
- Axle capacity, front, tyre dependent: 2500 kg (5511 lb)
- Axle capacity, rear, tyre dependent: 2500 kg (5511 lb)
- Gross vehicle weight: 3500 - 4000 kg (7716 - 8818 lb)
- Outer turning radius: 2550 - 2740 mm (100 - 108 in)
- Maximum speed: 40 km/h (25 mph)
- Sweeping width: 1200 - 2350 mm (47 - 92 in)
- Hopper volume: 1.5 m<sup>3</sup> (2 yd<sup>3</sup>)

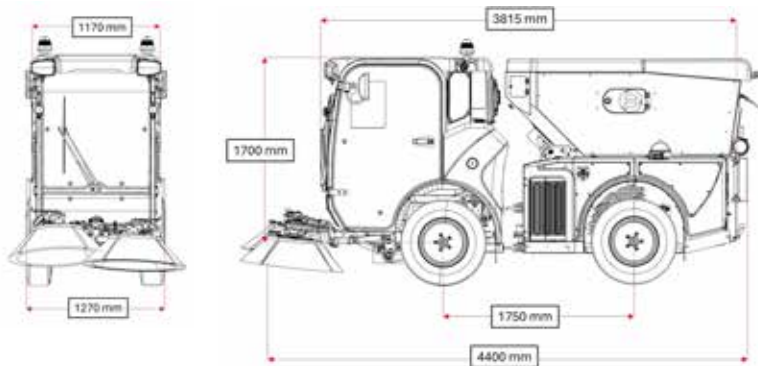

**CONTACT US**

**BOOK A CV DEMO TODAY!**

---



**YOUR LOCAL AUTHORISED DEALER IS:**



Multihog Global Headquarters,  
Finnabair Business Park, Dundalk, Co. Louth, A91 CY92, Ireland

+353 42 9386738 (EU/ROW) / 443 852 1842 (US/CA)  
[www.multihog.com](http://www.multihog.com)

**FOLLOW US:**

